

JHS

USER'S MANUAL

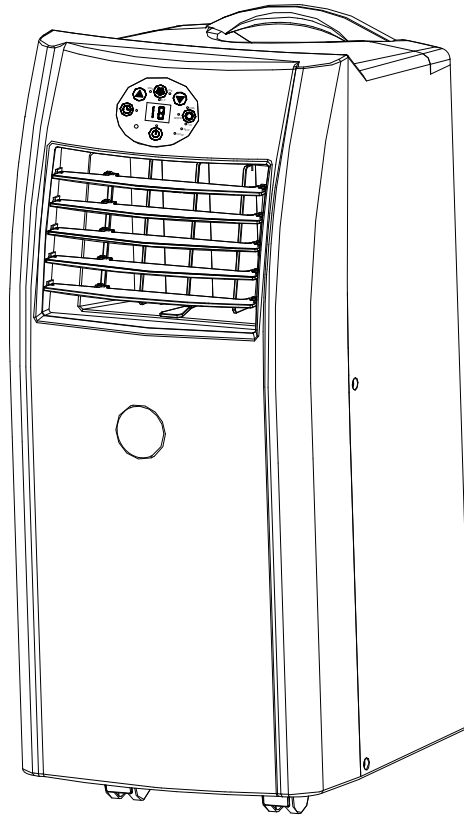

JHS-A001-07KRH/C

JHS-A001-08KRH/C

JHS-A001-09KRH/C

JHS-A001-10KRH/C SERIES

PORTABLE AIR CONDITIONER

Thank you for choosing super quality air conditioner. Please be sure to read this user's manual carefully before using the machine. Any problem, please contact the professional service for help.

CONTENTS

IMPORTANT SAFEGUARDS.....	3
PLACEMENT AND INSTALLATION.....	4
PARTS NAME.....	6
CONTROL PANEL.....	7
REMOTE CONTROL.....	8
OPERATION METHODS.....	8
WATER DRAINAGE.....	9
MAINTENANCE.....	10
TROUBLE SHOOTING.....	11

IMPORTANT SAFEGUARDS

Please read following safeguards carefully before using the machine:

- This machine just for domestic use, please don't use it in any other places.
- Please use this machine indoor not outdoor, and place it in a dry environment.
- Don't use the machine when any damage in power cord, plug or machine itself.
Any damage, please contact professional serviceman for help. If need to lengthen power cord, extended cord can be used, but please don't let the power cord scatter on the work area.
- Please make the machine far from heat sources and power supply , and avoid direct sunlight.
- Please turn-off the machine first before pull out the plug.
- Please pull out the plug when the machine is under cleaning, parts-replacement or leaving unused.
- Please clean the machine based on the instruction in user's manual.
- Please make sure using voltage meet requirements, the damages caused by connection error is out of the scope of warranty.
- Don't let little children touch the machine.
- Don't run the machine when no one there, even if a short leave, please turn-off it.
- Don't tug power cord when pulling out plug or moving the machine.
- Don't put the machine on a place with water or other liquid.
- Don't spatter water or oil into machine.
- Don't put hard objects between fan blades.
- Don't repair the machine by yourself. Dealing with problems by non-professional person may cause danger, even power cord replacement must be done by professional electrician.
- Only use accessories from suppliers, otherwise danger and damages of the machine may be caused .

Note :

- Place the machine on flat ground, and keep it far from around things at least 50cm.
- Make sure the socket can be reached from machine location.
- Keep the machine stand upright so that compressor can work well.
- Don't run the machine near to gasoline or any other flammable liquids.
- Make sure free access of air-inlet and air-outlet.
- Don't use spraying agent (such as pesticides , paint) or other flammable materials, otherwise plastic deformation, or even electric damage of the machine may be caused.

Power supply

- Make sure no damage in plug.
- Don't use connector instead of plug.
- Insert plug into socket first, then turn on socket switch , press key “POWER” to run machine.

Please safekeep this user's manual.

Placement and Installation

Placement

- Place the machine on flat and dry ground, and keep it far from around things at least 50cm. (fig.1)

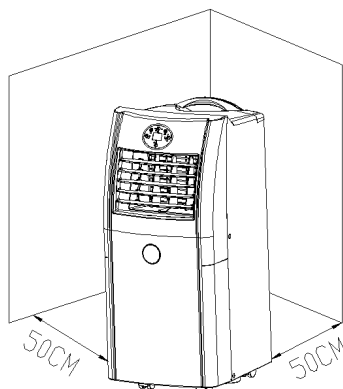

(fig.1)

Installation

- Spin adapter into exhaust pipe first, then spin the exhaust pipe into exhaust connector (counter-clockwise) (fig.2)
- Put adapter into window sealplate, adjust window open width in order sealplate match window well, and the length of sealplate is adjustable.

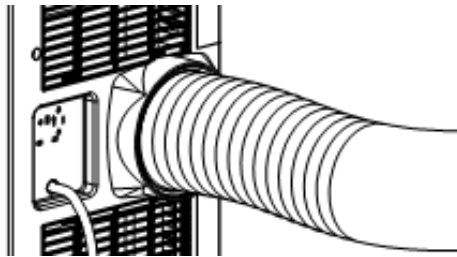

(fig.2)

Installation Errors

- Free access of exhaust pipe is important, installation errors will bring bad influence of machine.
- Avoid exhaust-pipe with sharp bend. (fig.3)
- Make sure air in exhaust pipe can run smoothly . (fig.4)

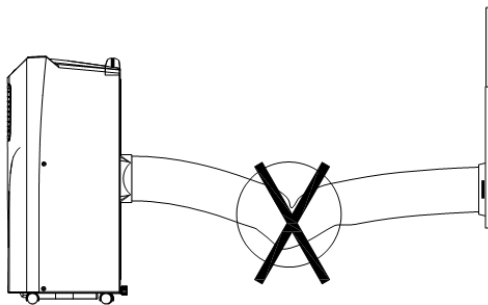

(fig.3)

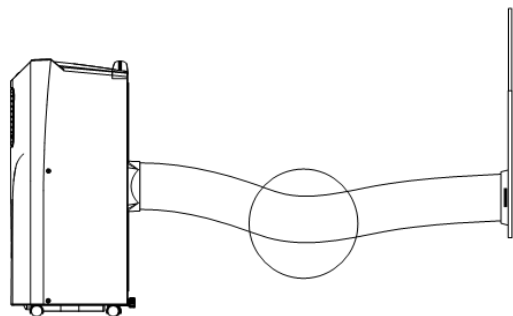

(fig.4)

Warning

Length of exhaust pipe according to the machine features, please don't replace or lengthen it freely, otherwise errors will be easily caused.

Note: extreme length of unfolding exhaust pipe is 1500mm, please shorten the length as much as possible and keep it level as much as possible when installing

Parts Name

Front side(fig.5)

1. Handle
2. Control Panel
3. Air-outlet
4. Fan blade
5. Castor

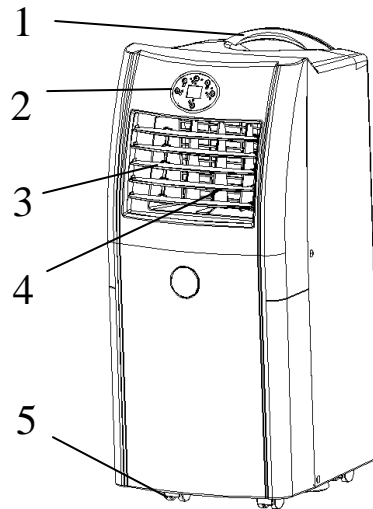

fig.5

Back Side(fig.6)

6. Filter frame upper
7. Exhaust Connector
8. Power Cord Location
9. Filter frame lower
10. Rubber plug
11. Plug cap
12. Power Cord

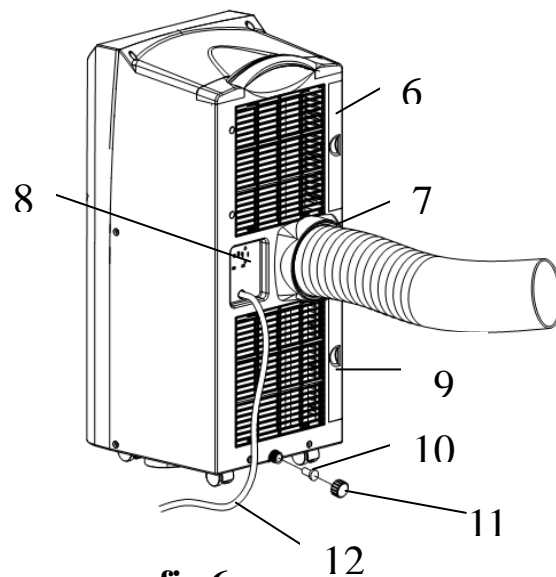
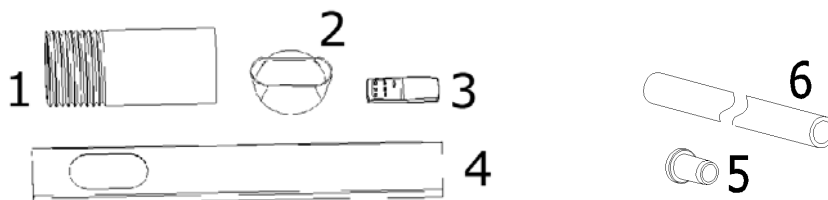

fig.6

Check packing accessories, read user's manual to get how to use them. (fig.7)



(fig.7)

- | | | | |
|--------------------|---------------------------|-------------------|--------------|
| 1. Exhaust Pipe | 2. Adapter | 3. Remote control | 4. Sealplate |
| 5. Drain connector | 6. Drain pipe (ID: 10mm) | | |

Control Panel

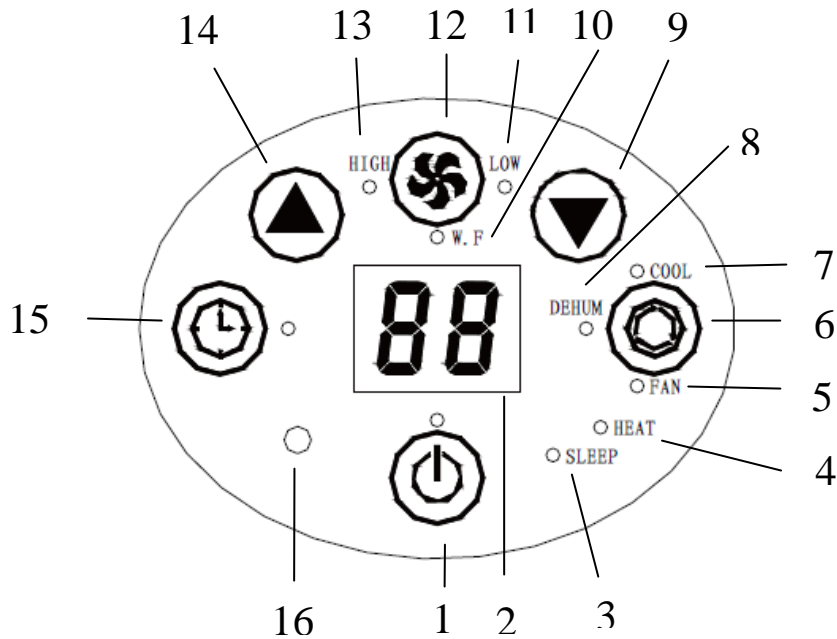

- | | |
|------------------------------|---------------------------------|
| 1. Power button | 9. Down button |
| 2. Display window | 10. "Water Full" indicator |
| 3. Sleep mode indicator | 11. Low fan indicator |
| 4. Heating mode indicator | 12. Fan button |
| 5. Fan mode indicator | 13. High fan indicator |
| 6. Mode button | 14. Up button |
| 7. Cooling mode indicator | 15. Timer button |
| 8. Dehumidify mode indicator | 16. Receiver for remote control |

1. POWER: press this key to turn on/off machine. After machine turns on, default value is cooling mode with low fan speed.
2. MODE: after machine turns on, press this key to select cooling, dehumidifying, fan and heating mode
3. FAN: after machine turns on, press this key to select fan speed (high and low).
4. DOWN: under cooling or heating mode, press this key to downward setting temperature from 16~31°C.
5. UP: under cooling or heating mode, press this key to upward temperature from 16~31°C.
6. SLEEP(on the remote control): under cooling or heating mode, press this key to turn on/off sleeping function.

7. **TIMER:** under power-on or standby mode, press this key to setup on/off time from 1~24.

Remote Control

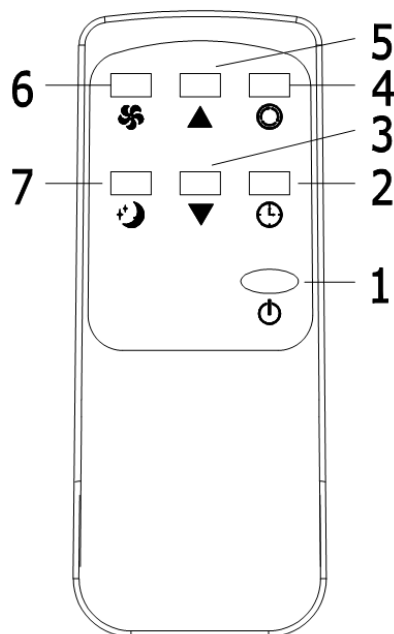

- | | | | |
|----------|----------|-------------|---------|
| 1. Power | 2. Timer | 3. Down | 4. Mode |
| 5. Up | 6. Fan | 7. Sleeping | |

Operation Methods

Cooling mode

- After machine turns on, default value is cooling mode with 22°C and low fan speed.
- Press “MODE” to select cooling mode, cooling mode indicator turns on .
- Press “UP” or “DOWN” to adjust temperature (from 16°C to 31°C).
- Press “FAN” to select high or low fan speed.

Heating mode

- Press “MODE” to select heating mode, heating mode indicator turns on.
- Press “UP” or “DOWN” to adjust temperature (from 16°C to 31°C).
- Press “FAN” to select high or low fan speed.

Note: When heating mode works, if don't want to empty the water-tank under this mode, please connect a water-drainage-pipe to remove the water out **continuously**.

Fan mode

- Press “MODE” to select fan mode, fan mode indicator turns on .
- Press “FAN” to select high speed or low speed.
- Temperature and sleeping function cannot be setup.

Timer mode

- Under standby mode, press “TIMER” to setup the power-on time. Timer indicator turns on.
- Under power-on mode, press “TIMER” to setup power-off timer. Timer indicator turns on.

Dehumidifying mode

- Press “MODE” to select dehumidifying mode, dehumidifying mode indicator turns on .
- Under dehumidifying mode, sleeping function cannot be setup, and fan speed is low.

Sleeping mode

- Press key “SLEEP” on the remote control enter into sleeping mode, default value of fan speed is low.
- When sleeping mode turns on , under cooling mode, the first one hour later, setting temperature will go up 1°C, the second one hour later, setting temperature will go up another 1°C, and then keep the same ; under heating mode, the first one hour later, setting temperature will go down 1°C, the second one hour later , the setting temperature will go down another 1°C, and then keep the same .
- Sleeping mode is invalid under dehumidifying and fan mode. Under water full, machine standby and mode conversion, sleeping mode will be cancelled .

Compressor protection

- Three minutes later after power on / restart, compressor starts to run.

Water Drainage

This machine with auto-water-evaporating system. Condensed-water cycle to cool down the condenser, which will not only improve cooling efficiency, but also save energy.

- If inner water tank is full, “W.F” indicator will flashed on the screen , 8 seconds later machine enter into standby mode, buzzer shouts , compressor stops and all keys is invalid till machine recovers to be normal .
- Pull out the plug to drain out water, power off the machine and restart it , the machine will runs normally .

Special caution for heating mode !

When heating mode works, if don't want to empty the water-tank under this mode, please connect a water-drainage-pipe to remove the water out continuously.

1. Remove the drain knob
2. Remove the rubber plug and keep it for future use
3. Fix the drain connector into the drain knob.
4. Fix the drain knob to the water-outlet of the unit.
5. Connect one end of the drain pipe (ID:10mm) into the water outlet as following and put the other end into a water-container.

Note: The water-container must be at or lower the outlet level.

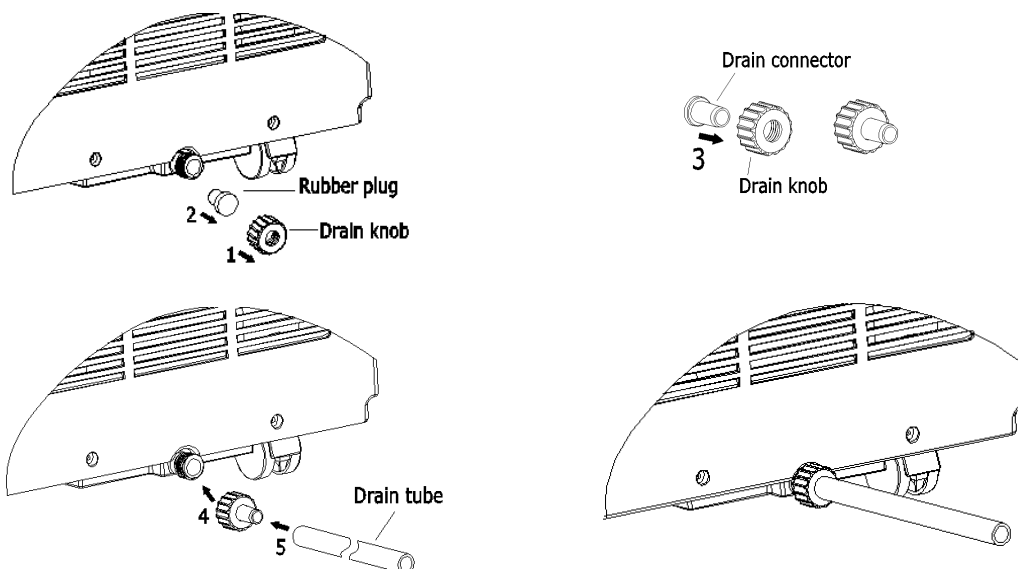

Maintenance

Note: in order to avoid electric shocks, please power-off the machine and pull out plug before maintenances or repairs.

Cleaning

- Please pull out plug before cleaning .
- Use soft semi-dry cloth to clean the machine. Don't use chemical agents, such as benzene, alcohol, gasoline and so on ; otherwise the machine surface will be damaged, or even the machine itself.
- Don't spatter water into the machine .

Filter

- Clean the filters every two weeks, if filters are blocked by dust, machine efficiency will be reduced .
- Clean the filters in warm water with neutral detergent, then dry the cleaned filters on a shady place.

Note: Don't run the machine without filters.

Season Cleaning

If the machine will be unused for a long time, please do as following :

- Pull out drainage plug upper / lower to flow out water.
- Let the machine runs under fan mode for 2 hours to dry out the machine internal
- Turn off machine and pull out plug .
- Clean and dry filters , then reinstall them .
- Pull out exhaust pipe for safekeeping .
- Put the machine into plastic bag , and place it on a dry place.

Trouble Shooting

Please contact professional serviceman without delay in following situation

Trouble	Cause	Solution
Machine cannot work	Power off	Power on
	water-full indicator turns on	Drain water out
Machine auto-restarts frequently	Direct sunlight	Draw the curtains
	Door and windows are open , many heat sources in the room .	Close the door and windows, move out heat sources.
	Filters are too dirty.	Clean or replace filters
	Air-inlet or air out-let is blocked	Remove blockage
Too noisy	Machine is not put on flat ground.	Place it on flat and solid ground, avoiding shaking
Compressor cannot work	Compressor time-delay protection turns on	Wait for 3 minutes, then restart the machine after temperature reduces .

Note: when abnormal situations are occurred, turn off machine and pull out plug, then contact with professional electrician for help .